

BRASS MANIFOLDS ZL-1125 SERIES

DATA SHEET AND INTALLATION

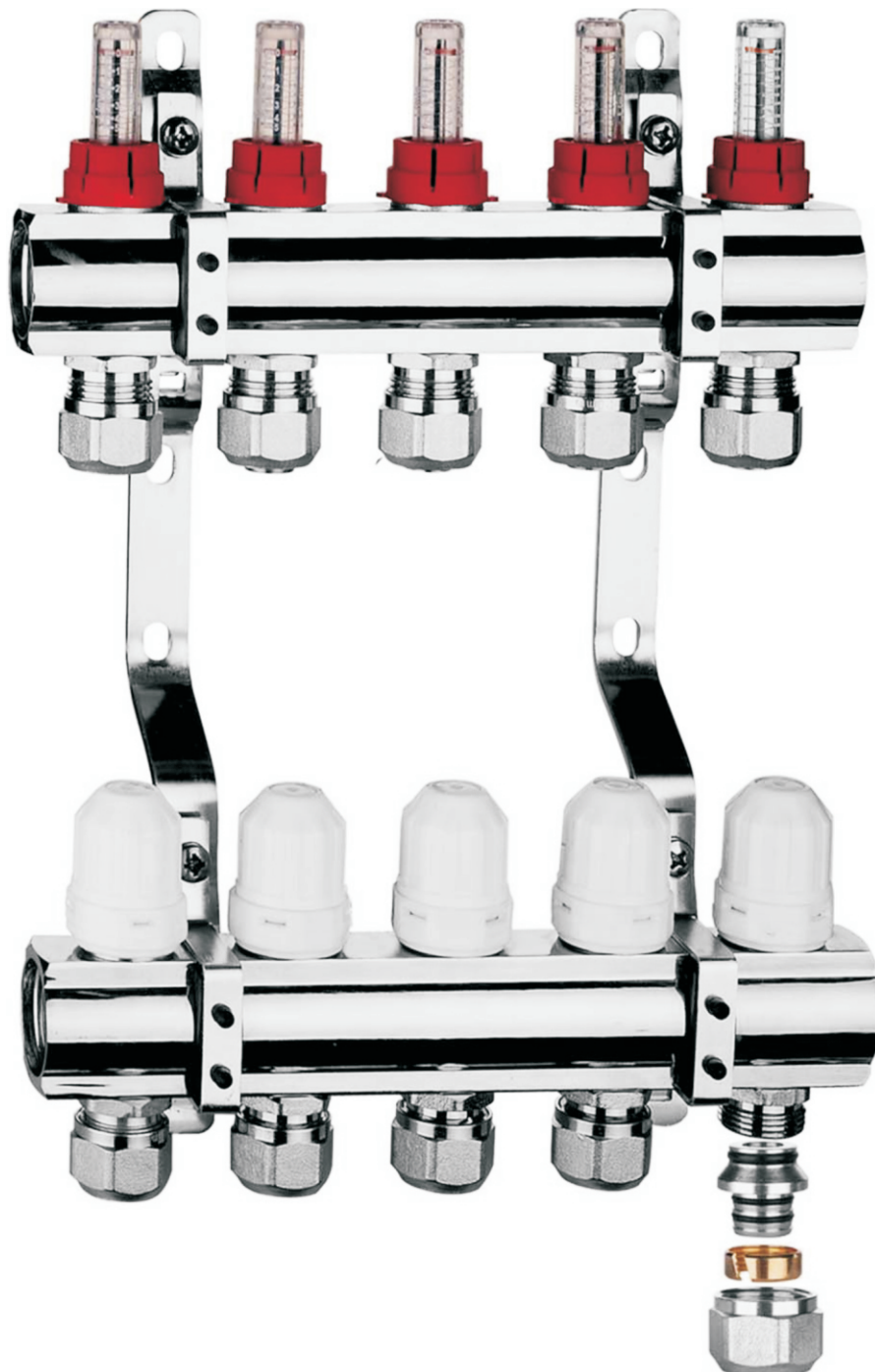



LINE DIAGRAM

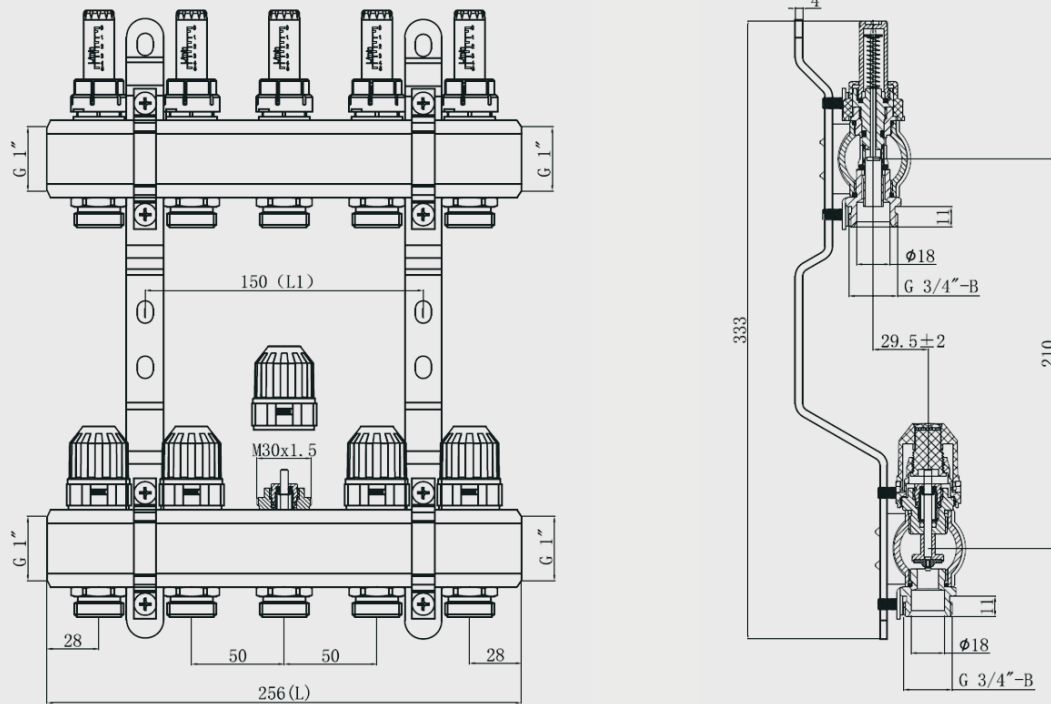

DESCRIPTION

The manifold is designed specifically for heating systems, and suitable for radiator heating and radiant floor heating systems.

The flow manifold is equipped with flow rate regulating valves, can accurately adjust the flow rate of each outlet; flow meter regulating valve is designed with protective cover, tighten the protective cover after the flow adjustment is completed, can prevent misoperation.

The return manifold is equipped with manual shut-off valves, in order to cut off the flow to the individual circuits. They can also be fitted with a thermo-electric actuator to realize automatic temperature control, The stroke of electro-thermal actuator should $\geq 3\text{mm}$.

Code	Outlets	L/mm	L1/mm
ZL1125002	2	106	-
ZL1125003	3	156	50
ZL1125004	4	206	100
ZL1125005	5	256	150
ZL1125006	6	306	200
ZL1125007	7	356	250
ZL1125008	8	406	300
ZL1125009	9	456	350
ZL1125010	10	506	400
ZL1125011	11	556	450
ZL1125012	12	606	500

TECHNICAL SPECIFICATIONS

Body	Brass
Hydraulic Seals	EPDM
Flyers & Caps	ABS
Springs	Stainless Steel
Brackets	Steel
Adaptors	Brass

PERFORMANCE

Medium	water, glycol solution Max. percentage of glycol is 30%
Working temperature range	5~100°C
Maximum working pressure	10bar
Flow meter scale	0~5L/min
Main connections	1" F (ISO 228-1)
Outlets	3/4" M (ISO 228-1)
Centre distance	50mm



CHARACTERISTIC COMPONENTS

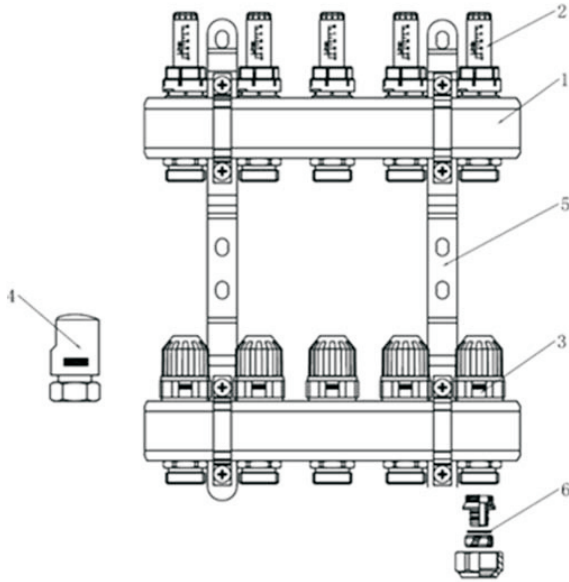

NO.	COMPONENTS	DESCRIPTIONS
1	Manifold Body	Made of high quality brass
2	Flow rate regulation valve	Accurately adjust the flow rate of each outlet
3	Shut-off valve	cut off the flow to the individual circuits
4	Electrothermal actuator	Automatic temperature control
5	Brackets	Pair of mounting brackets for manifold box or wall installation
6	Adaptor	Connect the pipe and manifold

HYDRAULIC CHARACTERISTICS

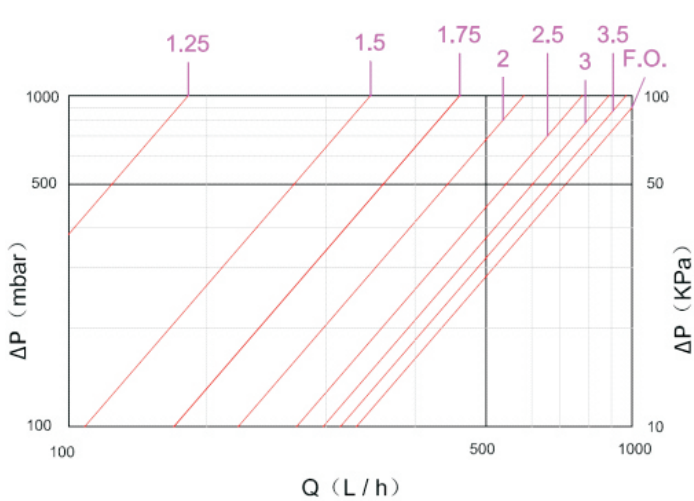

Turns	1.25	1.5	1.75	2	2.5	3	3.5	F.O.
Kv	0.12	0.33	0.47	0.57	0.77	0.88	0.95	1.02

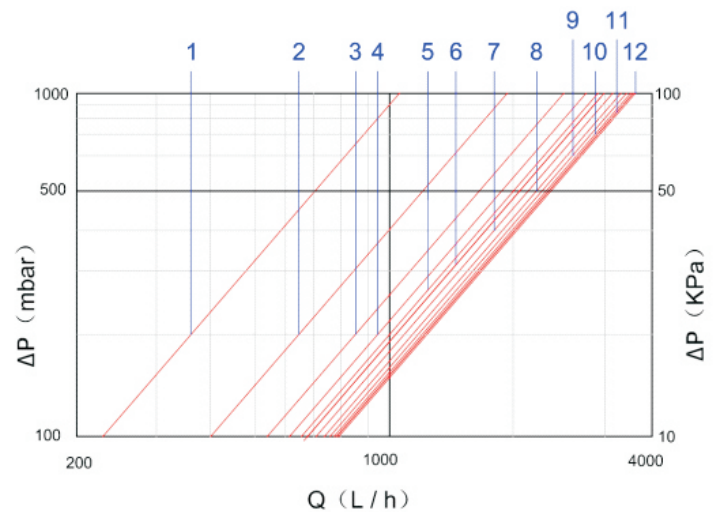

NO. of outlets	1	2	3	4	5	6	7	8	9	10	11	12
Kv	1.02	1.65	2.23	2.55	2.81	2.97	3.13	3.26	3.34	3.38	3.42	3.50



Installation instructions

1. Take out the manifold from the packaging box, observe whether there is damage, missing parts or other problems;
2. Fix the assembled manifold on the wall with expansion bolts, and the brackets of the manifold is about 30cm high from the ground;
3. Cut the multilayer pipe in a perpendicular way and then calibrate it, the cut shall be kept round;
4. Put the hexagon nut and cutting sleeve on the pipe in turns, and push down 3-5cm, cover the hose union with a flat gasket and then place them into the pipe;
5. Insert the hose union into the threaded terminals of the manifold, and ensure that the O-ring is not misplaced or deformed, and turn the hexagon nut manually;
6. Hold the fitting on the manifold with a wrench and tighten the hexagon nut with another wrench.

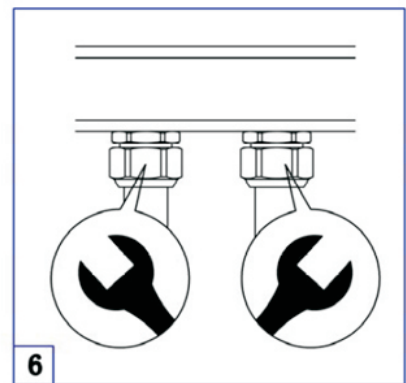
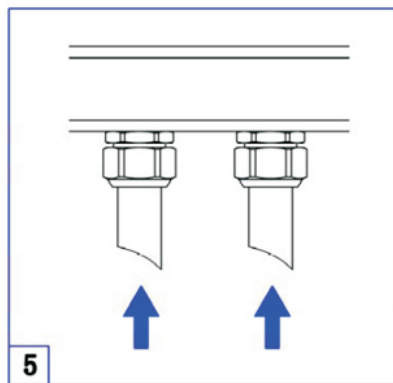
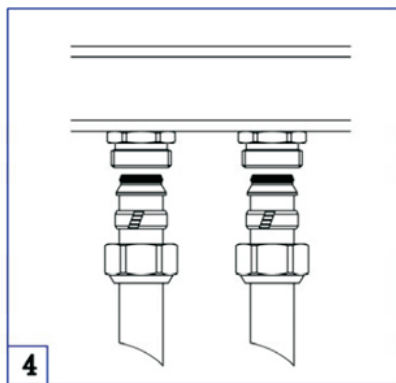
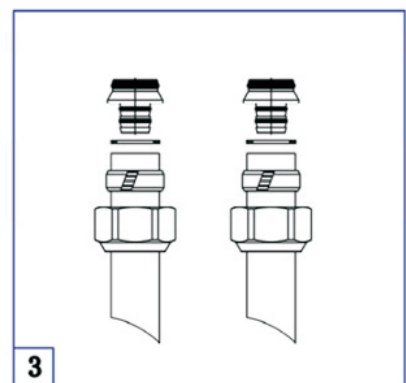
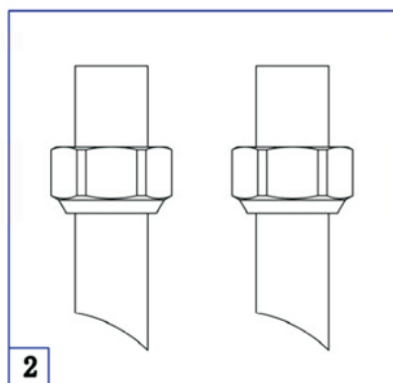
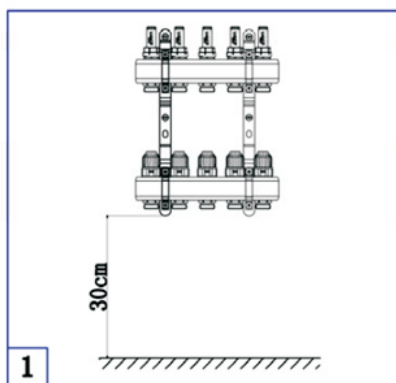

Notes

1. The flow manifold and the return manifold should be provided with a valve, and the valve of the flow manifold should have a filter device; Bypass valve should be set between the flow manifold and the return manifold;
2. Excessive installation torque will lead to thread breakage, sealing ring damage, resulting in product leakage. Valve installation torque is about 40NM, pipe installation torque is about 20NM;
3. If the electro-thermal actuator is installed, wrench, pliers, screwdriver and other tools cannot be used, only tighten manually;
4. When installation, the tool must be stuck in the hexagonal surface for rotation, cannot be stuck in other positions;



5. For the central heating area, if the water temperature exceeds 60 degrees Celsius, mixed water cooling device should be installed; For floor heating and radiator mixed installation customers, mixed water cooling device should be installed;

6. The length of each loop connected to the same manifold should be similar, and the single loop should not exceed 120m;

7. Working pressure generally does not exceed 0.6Mpa, if the system pressure changes greatly, a pressure reducing valve can be installed in the front end of the system, to prevent the damage of the pipe or other accessories due to the excessive pressure;

8. Pressure test shall be carried out after the installation of the system, the test pressure shall not be less than 0.6-0.8mpa, and the test time shall not be less than 24h.

Operation instructions

Each branch of the flow manifold is equipped with a flow rate regulating valve to regulate and cut off the flow. Remove the red protective caps from the flowmeters; Set the flowmeter adjustment to the project value by manually rotating the handwheel indicated by the arrow; Screw the red “memory stop” ring nut counter-clockwise until it reaches the end of the stroke; Turning the handwheel clockwise, it is possible to close the single circuit. Turning the handwheel counterclockwise, the circuit will re-open up to the set project value.

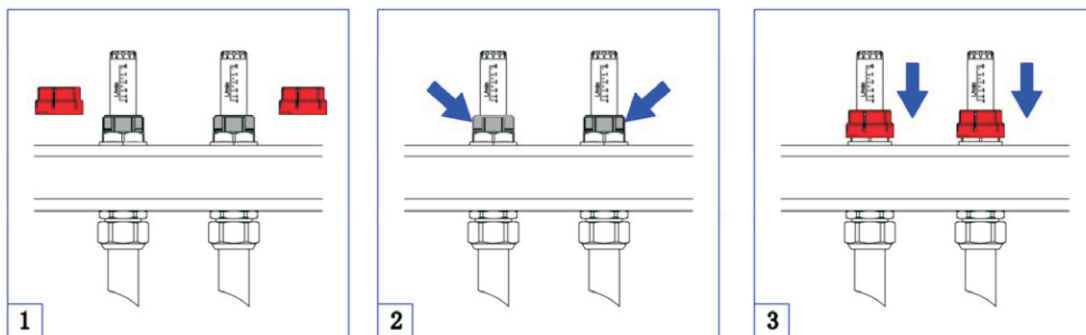

Each branch on the return manifold is equipped with manual shut-off valves, which can be switched on and off by rotating the handwheel. The plastic handwheel can be replaced by an electro-thermal actuator, which is connected with the indoor temperature controller in the branch area. After the temperature reaches the set temperature, the electro-thermal actuator automatically closes the branch.

Notes

1. When the first heating or re-heating, exhaust the gas in the pipeline with exhaust device, to ensure a normal circulation flow; In the heating period, the manual exhaust device is used irregularly to discharge the gas in the pipeline to ensure the heating effect;

2. When you are not at home for a long time, the total circulating water volume of the manifold shall be adjusted to a small size. Do not close it all! If there is no need heating in winter, the water in the pipeline should be drained clean, so as to not freeze the pipeline and manifold;

3. The seals of the manifold are wearing parts. It should be checked regularly during installation and use to prevent water seepage caused by the damage of the seal, and bring unnecessary losses.

4. The filter installed should be cleaned at least once a year;

5. At the end of the annual heating period, the water in the pipeline should be discharged clean, so as to prolong the service life of the manifold.