

# Preassembled Manifolds with Flow Meters and Multifunction Valves ZL-1200 Installation and operation instruction

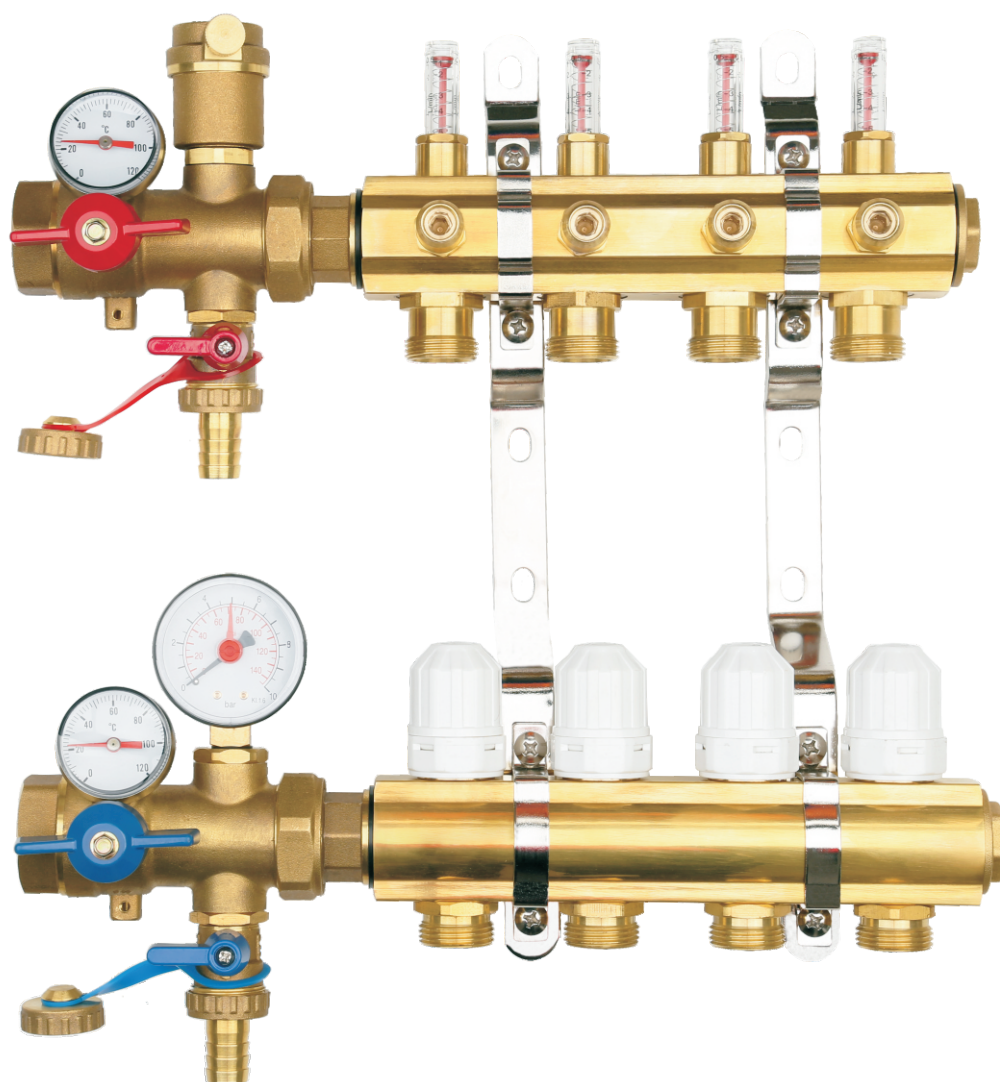

## Description

The manifold consisting of:

☞ One delivery and return manifold, formed of a delivery bar with front balancing lockshield valves equipped with a mechanical memory and flow meters, and a return bar with shut-off valves with handwheel, suitable for electro-thermal command.

☞ Pair of multifunction valves, ZL4460 series, complete with terminal plugs for the manifold.

Installed upstream of the manifold, they integrate the following functions:

- Ball shut-off valves
- Air vent valves
- Filler/drain cocks
- Contact thermometers
- Inputs for immersion temperature probes  $\varnothing$  6 mm

☞ This product has two options of tempering and nickel plating, please make notes in the order.

## Technical Specifications

### Materials

Manifold and terminal plugs	Brass
Multifunction valves	Brass
Seals	EPDM
Handwheel	ABS
Brackets	Steel

### Performance

Working temperature range	5~100°C
Maximum working pressure	10bar
Flow meter scale	0.5~5L/min
Main connections	1" F (ISO 228-1)
Outlets	3/4" M (ISO 228-1)
Centre distance	50mm

## Dimensions

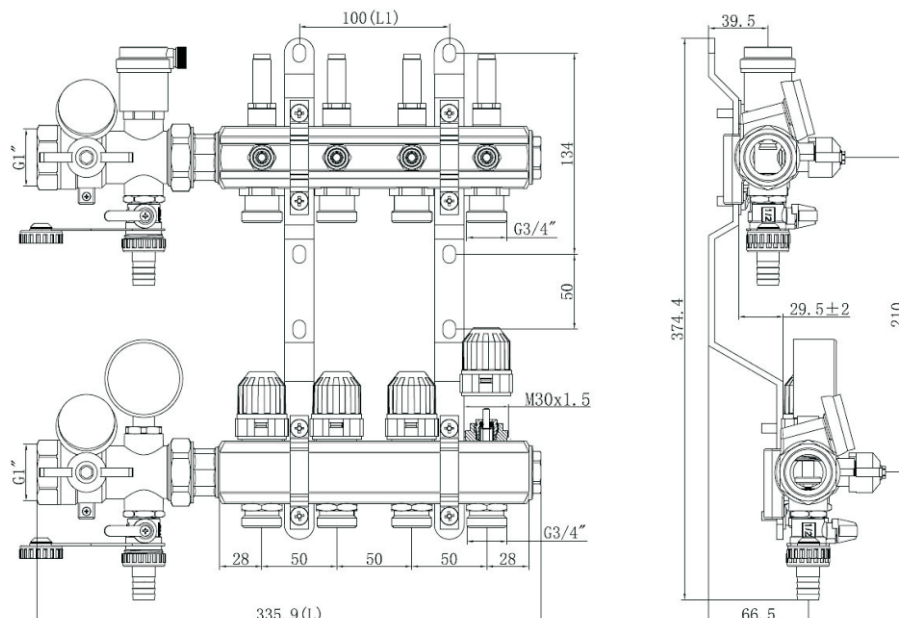

Code	No. of outlets	L/mm	L1/mm
ZL1200002	2	236	-
ZL1200003	3	286	50
ZL1200004	4	336	100
ZL1200005	5	386	150
ZL1200006	6	436	200
ZL1200007	7	486	250
ZL1200008	8	536	300
ZL1200009	9	586	350
ZL1200010	10	636	400
ZL1200011	11	686	450
ZL1200012	12	736	500

## Hydraulic Characteristics

Losses of pressure of single circuit:

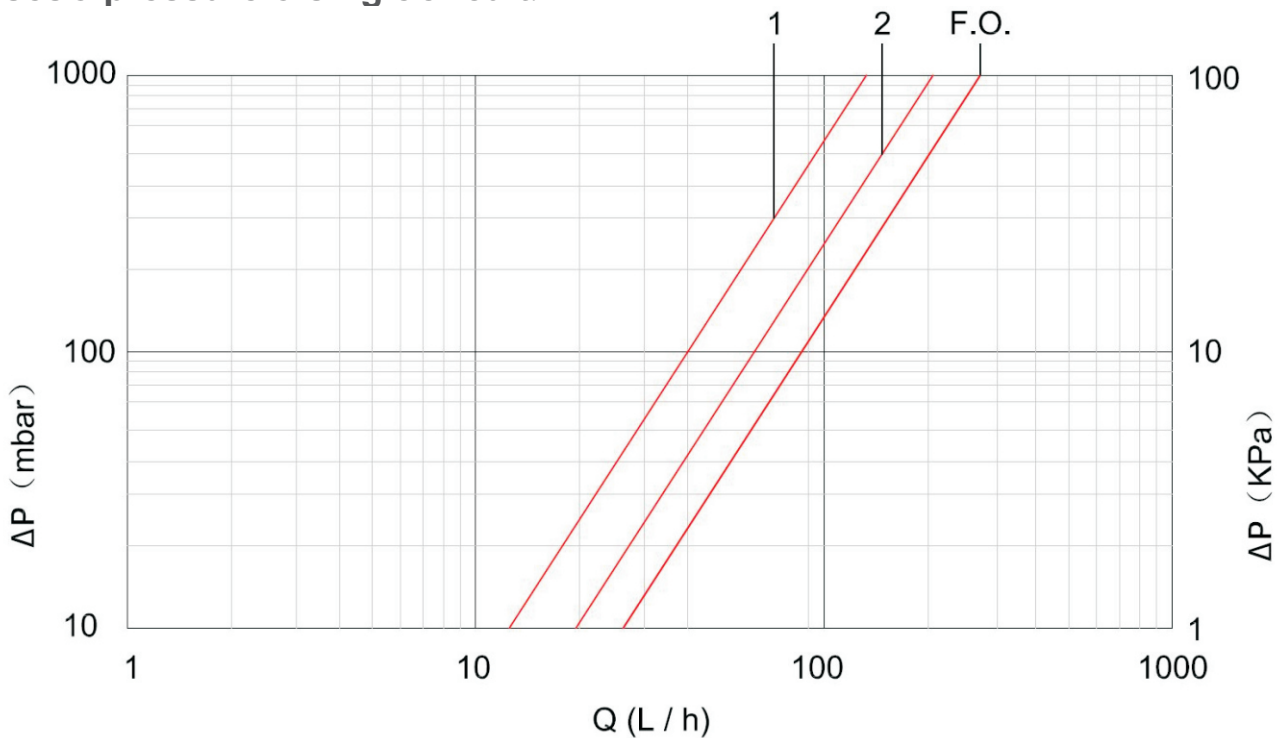

NO. of lockshield valve turns	1	2	F.O.
Kv	0.47	0.73	0.85

## Installation

∞ Install the ZL4460series multifunction valves upstream from the manifold.

They can easily be assembled with the input on the left or right, thanks to the self-sealing device on the air vent valve and filler/drain cock.

Input from the left

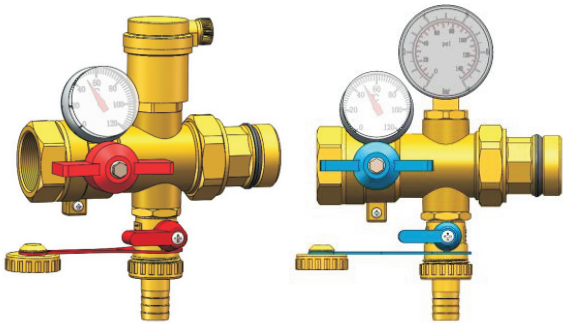

Input from the right

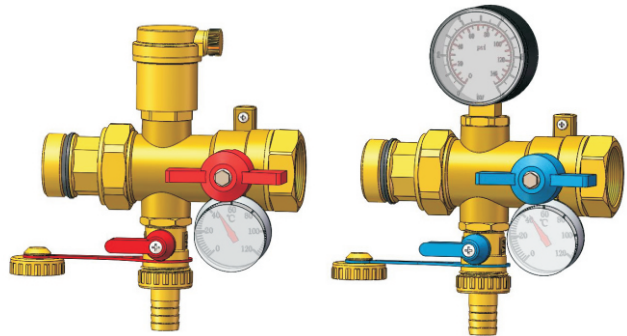

∞ Install the manifold - complete with the metal supports, multifunction valves and plugs - inside the cabinets, Connect the system pipes to the manifold units.

1. Take out the manifold from the packaging box, observe whether there is damage, missing parts or other problems;
2. Fix the assembled manifold on the wall with expansion bolts, and the brackets of the manifold is about 30cm high from the ground;
3. Cut the multilayer pipe in a perpendicular way and then calibrate it, the cut shall be kept round;
4. Put the hexagon nut and cutting sleeve on the pipe in turns, and push down 3~5cm, cover the hose union with a flat gasket and then place them into the pipe;
5. Insert the hose union into the threaded terminals of the manifold, and ensure that the O-ring is not misplaced or deformed, and turn the hexagon nut manually;
6. Hold the fitting on the manifold with a wrench and tighten the hexagon nut with another wrench.

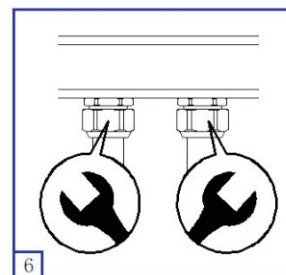
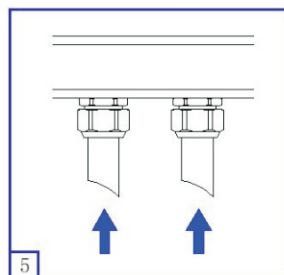
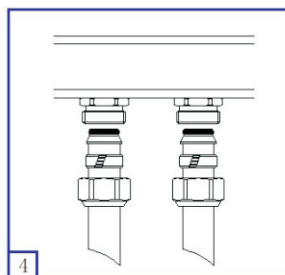
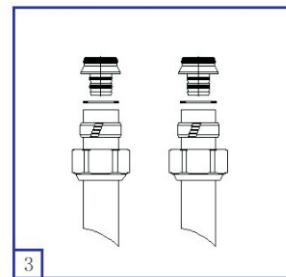
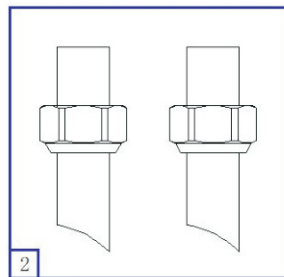
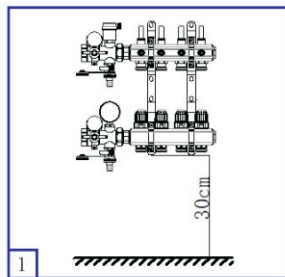

## Notes

1. The flow manifold and the return manifold should be provided with a valve, and the valve of the flow manifold should have a filter device; Bypass valve should be set between the flow manifold and the return manifold;
2. Excessive installation torque will lead to thread breakage, sealing ring damage, resulting in product leakage. Valve installation torque is about 40NM, pipe installation torque is about 20NM;
3. If the electro-thermal actuator is installed, wrench, pliers, screwdriver and other tools cannot be used, only tighten manually;
4. When installation, the tool must be stuck in the hexagonal surface for rotation, cannot be stuck in other positions;
5. For the central heating area, if the water temperature exceeds 60 degrees Celsius, mixed water cooling device should be installed; For floor heating and radiator mixed installation customers, mixed water cooling device should be installed;
6. The length of each loop connected to the same manifold should be similar, and the single loop should not exceed 120m;
7. Working pressure generally does not exceed 0.6Mpa, if the system pressure changes greatly, a pressure reducing valve can be installed in the front end of the system, to prevent the damage of the pipe or other accessories due to the excessive pressure;
8. Pressure test shall be carried out after the installation of the system, the test pressure shall not be less than 0.6-0.8mpa, and the test time shall not be less than 24h.

## Operation

To make the adjustment the first step is the complete opening of the mechanical memory with a SW7 Allen key. Then with a SW5 Allen key you must open the lockshield until the required value. After this you must close the mechanical memory with SW7 Allen key.

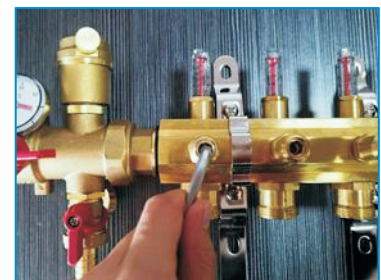

Automatic temperature control for every room is possible by installing electrical actuator normally closed or normally open. To install the electrical actuator you have to remove the handwheel of the shut-off valve

